

**MITSUBISHI
ELECTRIC**
INVERTER
FR-A800/F800



Safety Stop Function Instruction Manual

CONTENTS

1. GENERAL DESCRIPTION	2
2. INSTALLATION AND WIRING.....	3
3. EXAMPLE OF SAFETY SYSTEM CONFIGURATION	7
4. TEST AND CHECKING FAILURE	10
5. SAFETY PARAMETERS OF FR-A800/F800	11

Compliance with the EU Machinery Directive – Functional Safety

WARNING

- Any misuse of safety function could lead to personal injury or death, property damage, or economic loss. To ensure that the system complies fully with requirement of safety, make a system-level risk assessment. Mitsubishi Electric Co. cannot assume responsibility for any system to comply with safety directive.

CAUTION

- The information of this manual is merely a guide for proper installation.
- Mitsubishi Electric Co. cannot assume responsibility for the compliance or the noncompliance to any code, national, local or otherwise for the proper installation of this equipment.
- A hazard of personal injury and/or equipment damage exists if codes are ignored during installation.

WARNING

- To avoid an electric shock hazard, verify that the voltage on the bus capacitors has discharged before performing any work on the drive. Measure the DC bus voltage at the P(+) and N(-) terminals or test points (refer to your drive's [User Manual](#) for locations and discharging time). The voltage must be zero.

WARNING

- The safety stop function do not isolate electrically between drive and motor. To avoid an electric shock hazard, disconnect/isolate power to the drive and verify to ensure that the voltage is zero before performing any work on the motor (refer to your drive's [User Manual](#) for discharging time).

1 GENERAL DESCRIPTION

Features

Mitsubishi FR-A800/F800 safety stop function prevents a drive from supplying rotational energy to motors. Dual safety channels 'S1' and 'S2' cut off the gate-drive power for IGBT to turn off.

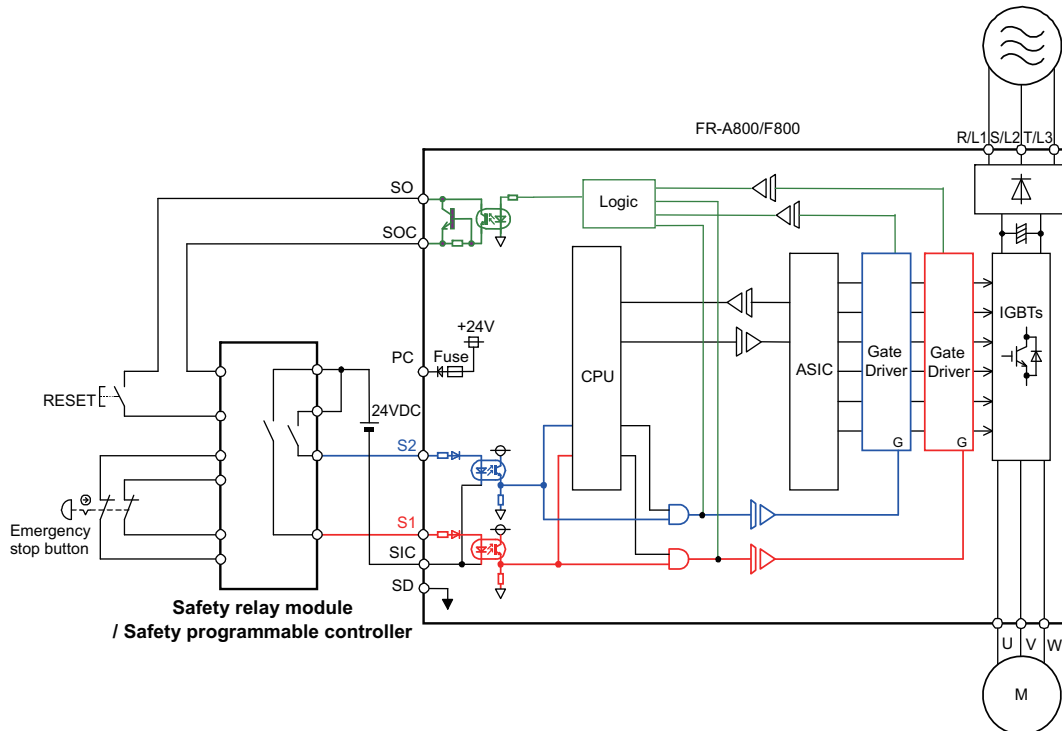

Fig.1 FR-A800/F800 safety stop function diagram

⚠ WARNING

- Disconnecting the power to the gate driver by the safety stop function does not isolate electrically between drive and motor. To avoid an electric shock hazard, disconnect power to the drive and verify that the main circuit capacitor voltage is zero (across P and N terminals) before performing any work on the motor (refer to your drive's [User Manual](#) for discharging time).

Standards

Mitsubishi FR-A800/F800 safety stop function meets the following directives and categories.

ISO13849-1:2008 Category 3/PLd

IEC62061:2005 / IEC61800-5-2:2007 / IEC61508 SIL2

IEC60204-1:2010 / IEC61800-5-2:2007 Stop category 0

⚠ WARNING

- The misuse of safety function leads to personal injury or death, property damage, or economic loss. To ensure that the system complies fully with requirement of safety, make a system-level risk assessment. Mitsubishi Electric Co. cannot assume responsibility for any system to comply with safety directive.

2 INSTALLATION AND WIRING

⚠ CAUTION

- The following information is merely a guide for proper installation.
- Mitsubishi Electric Co. cannot assume responsibility for the compliance or the noncompliance to any code, national, local or otherwise for the proper installation of this equipment.
- A hazard of personal injury and/or equipment damage exists if codes are ignored during installation.

⚠ CAUTION

- Ensure the safety relay unit and the FR-A800/F800 unit is mounted closely in enclosure meeting IP54 and all interconnection wiring is short and protected against open and short circuit faults. Refer ISO/IEC13849-2.

Installation

Mitsubishi FR-A800/F800 safety stop function should be used under following condition and environment.

Table.1 The condition and environment for using safety stop function

Item		Condition
Surrounding air temperature	LD, ND, HD *1	-10°C to +50°C (non-freezing)
	SLD	-10°C to +40°C (non-freezing)
Storage temperature		-20°C to +65°C *2
Ambient humidity		With circuit board coating (conforming to IEC60721-3-3 3C2/3S2): 95% RH or less (non-condensing), Without circuit board coating: 90% RH or less (non-condensing)
Vibration		5.9m/s ² or less at 10 to 55Hz (directions of X, Y, Z axes)
Altitude		Maximum 2500 above sea level *3
Atmosphere		Indoors (free from corrosive gas, flammable gas, oil mist, dust and dirt)
Over voltage category		III or less
Pollution degree		II or less
Mounting		Wall mounting / vertical orientation

*1 The ND and HD ratings can be selected only for the FR-A800.

*2 Temperature applicable for a short time, e.g. in transit.

*3 For the installation at an altitude above 1,000 m (3280.80 feet) up to 2,500 m (8202 feet), derate the rated current 3% per 500 m (1640.40 feet).

⚠ CAUTION

- In order to meet safety stop, an approved safety relay unit to ISO13849-1 safety category 3 or better shall be used in conjunction with FR-A800/F800 as shown in example. In addition, all other components within the safety stop loop shall be 'safety approved' types.

⚠ WARNING

- To avoid an electric shock hazard, insert the magnetic contactor (MC) between power source and drive.
- Open the contact of MC and keep away from drive for discharging time (refer to your drive's User Manual for information) before performing any work on the drive. And verify that the voltage on the bus capacitors has discharged before measuring the DC bus voltage at the P(+) and N(-) terminals or test points (refer to your drive's User Manual for locations). The voltage must be zero.

⚠ CAUTION

- To avoid systematic faults, a test even for faulty demands of the safety function has to be performed in order to check the correct function of the monitor signal. This test shall be carried out at system installation, any software changes, parameterization changes, and/or at least once per year. Refer to '4. Test and checking failure'.

●Wiring

The safety related terminals are described in Table.2 and Table.3

Table.2 The safety related terminals

Terminal symbol	Description *2	Rating *1
S1	For input of safety stop channel 1. S1-SIC is OFF: In safety stop mode. ON: Non safety stop mode.	Input resistance: 4.7kΩ Input current : 4 to 6 mADC (In case of 24VDC input)
S2	For input of safety stop channel 2. S2-SIC is OFF: In safety stop mode. ON: Non safety stop mode.	
SIC	Common terminal for S1 terminal and S2 terminal.	
SO	As output for failure detection and alarm. SO terminal type is 'Open collector output'. SO-SOC is OFF: Detect failure or alarm. ON: No failure detected. Note: This terminal cannot be used to output safety outputs in a safety system. This terminal can be used for alarm or to prevent restart only, no other safety function.	Load: 24VDC/0.1A max. Voltage drop: 3.4V max. (In case of 'ON' state)
SOC	Common terminal for SO terminal.	

*1 Specifications for conforming safety standards.

*2 ON: The transistor is conducted. OFF: The transistor is not conducted.

Table.3 Truth table of safety related signals

Input power	Internal safety circuit status	Input terminal *1, *2		Output terminal	Inverter running status	Operation panel indication	
		S1	S2	SO		E.SAF *6	SA *7
OFF	—	—	—	OFF	Output shutoff (Safe state)	Not displayed	Not displayed
ON	Normal	ON	ON	ON *3	Drive enabled	Not displayed	Not displayed
	Normal	ON	OFF	OFF *4	Output shutoff (Safe state)	Displayed	Displayed
	Normal	OFF	ON	OFF *4	Output shutoff (Safe state)	Displayed	Displayed
	Normal	OFF	OFF	ON *3	Output shutoff (Safe state)	Not displayed	Displayed
	Fault	ON	ON	OFF	Output shutoff (Safe state)	Displayed	Not displayed *5
	Fault	ON	OFF	OFF	Output shutoff (Safe state)	Displayed	Displayed
	Fault	OFF	ON	OFF	Output shutoff (Safe state)	Displayed	Displayed
	Fault	OFF	OFF	OFF	Output shutoff (Safe state)	Displayed	Displayed

*1 ON: The transistor is conducted. OFF: The transistor is not conducted.

*2 When not using the safety stop function, short across terminals S1 and PC, S2 and PC, and SIC and SD to use the inverter. (In the initial status, terminals S1 and PC, S2 and PC, and SIC and SD are respectively shorted with shorting wires.)

*3 If any of the protective functions shown in the following table is activated, the terminal SO turns OFF.

Error definition	Operation panel indication
Option fault.	E.OPT
Communication option fault	E.OP1
Parameter storage device fault	E.PE
Retry count excess	E.RET
Parameter storage device fault	E.PE2
Operation panel power supply short circuit/ RS-485 terminals power supply short circuit	E.CTE

Error definition	Operation panel indication
24 VDC power fault	E.P24
Safety circuit fault	E.SAF
Overspeed occurrence	E.OS
CPU fault	E.CPU
	E.5 to E.7
Internal circuit fault	E.13

*4 If the internal safety circuit is operated normally, the terminal SO remains ON until E.SAF is displayed, and the terminal SO turns OFF when E.SAF is displayed.

*5 SA is displayed when the terminals S1 and S2 are identified as OFF due to the internal safety circuit failure.

*6 If another fault occurs at the same time as E.SAF, the other fault can be displayed.

*7 If another warning occurs at the same time as SA, the other warning can be displayed.

NOTE

- The response time from safety stop signal input to drive shutoff (safe state) is faster than 8ms.
- Hold the ON or OFF status for 2ms or longer to input signal to terminal S1 or S2. Signal input shorter than 2ms is not recognized.

●Wire and ferrule specification

Table.4 Wire and ferrule specification

Wire size (mm ²)	Ferrule with insulation collar *1	Crimping tool name *1
0.3 / 0.5	AI 0,5-10WH	CRIMPFOX 6
0.75	AI 0,75-10GY	
1	AI 1-10RD	
1.25 / 1.5	AI1,5-10BK	
0.75 (combined 2 wire)	AI TWIN 2 X 0,75-10GY	

*1 Ferrules and tools are distributed by Phoenix Contact.

●Jumper cable

The jumper cable between S1,S2 and PC terminal between SIC and SD terminal has been installed in the factory as shown in Fig.2.

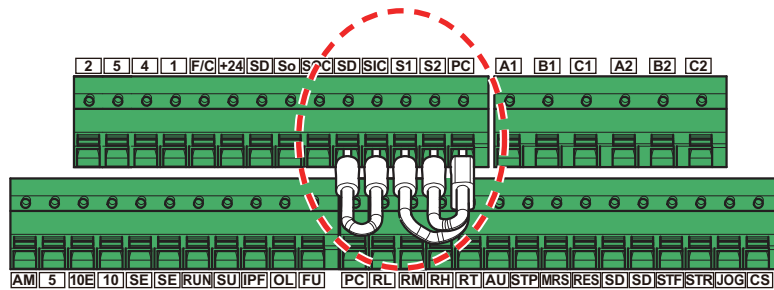

Terminal block of FR-A800/F800

Fig.2. Short wire

Before connecting safety input wire to S1,S2 and SIC terminal, remove this jumper cable.

3 EXAMPLE OF SAFETY SYSTEM CONFIGURATION

•FR-A800/F800 configuration example

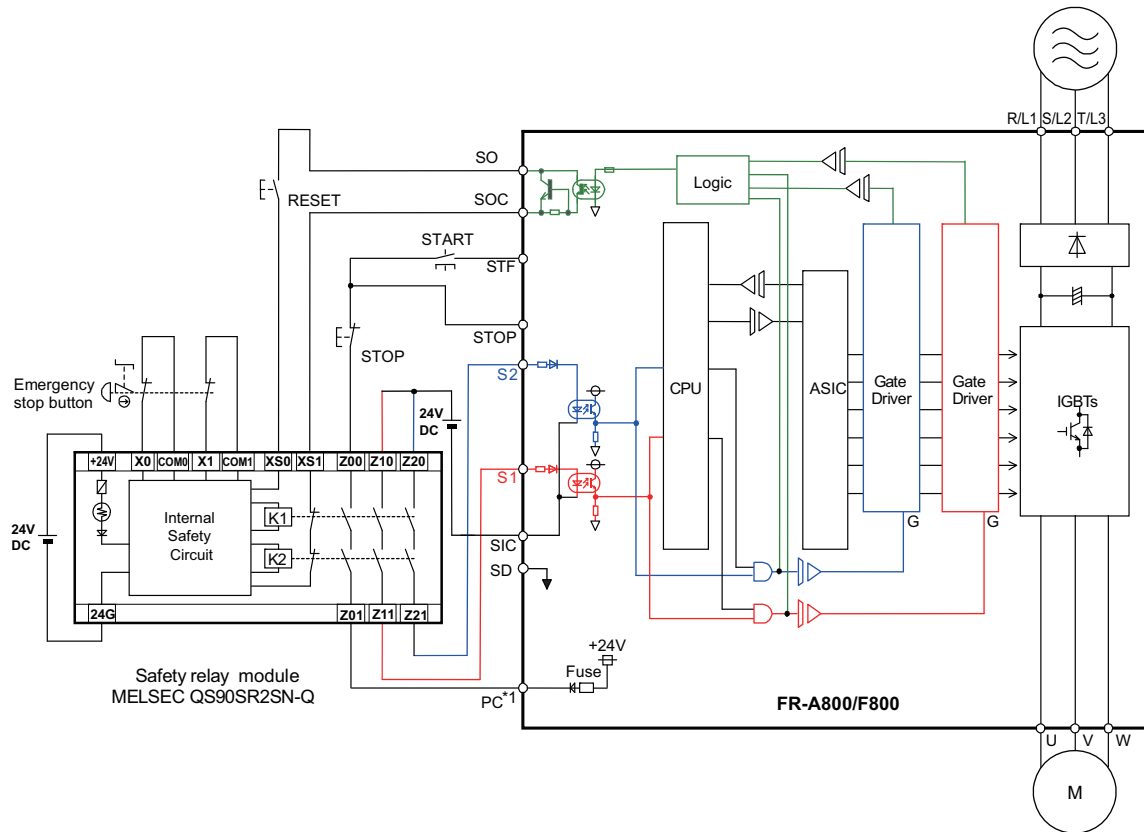

*1 If the control logic is SINK logic, the common terminal is terminal SD.

Fig.3 Safety system example with FR-A800/F800

NOTE

- When starting up the system's operation, press the RESET switch to reset the safety stop function first, then turn ON the START switch to run the motor.
- In the above configuration, after reset of emergency stop button, drive will be in safe-state until RESET switch is pressed.

CAUTION

- To prevent restart in case of recovering from input power loss of drive, 3-wired connection for START/STOP control is recommended. In case of 2-wire connection and using latching type switch to short between STF and SD/PC for starting, ensure the compliance with safety requirement for the restarting when the drive recover from input power loss.

● Multiple inverter configuration example

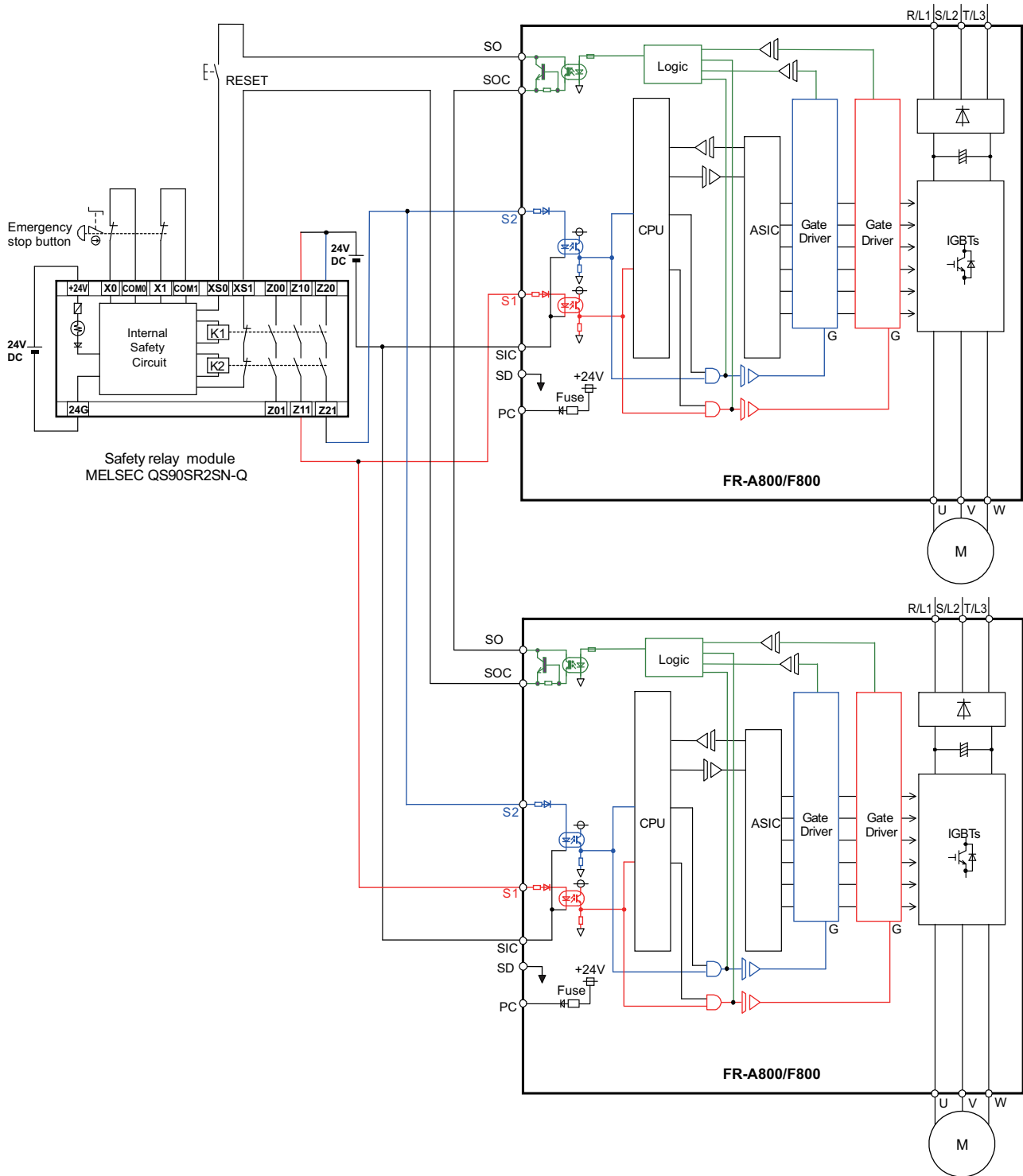

Fig.4 When using multiple safety stop function inverters (FR-A800/F800)

NOTE

- Some models cannot be used together because their control logics are different. Refer to the [SAFETY STOP FUNCTION MANUAL](#) of each model.

● Safety controller configuration example

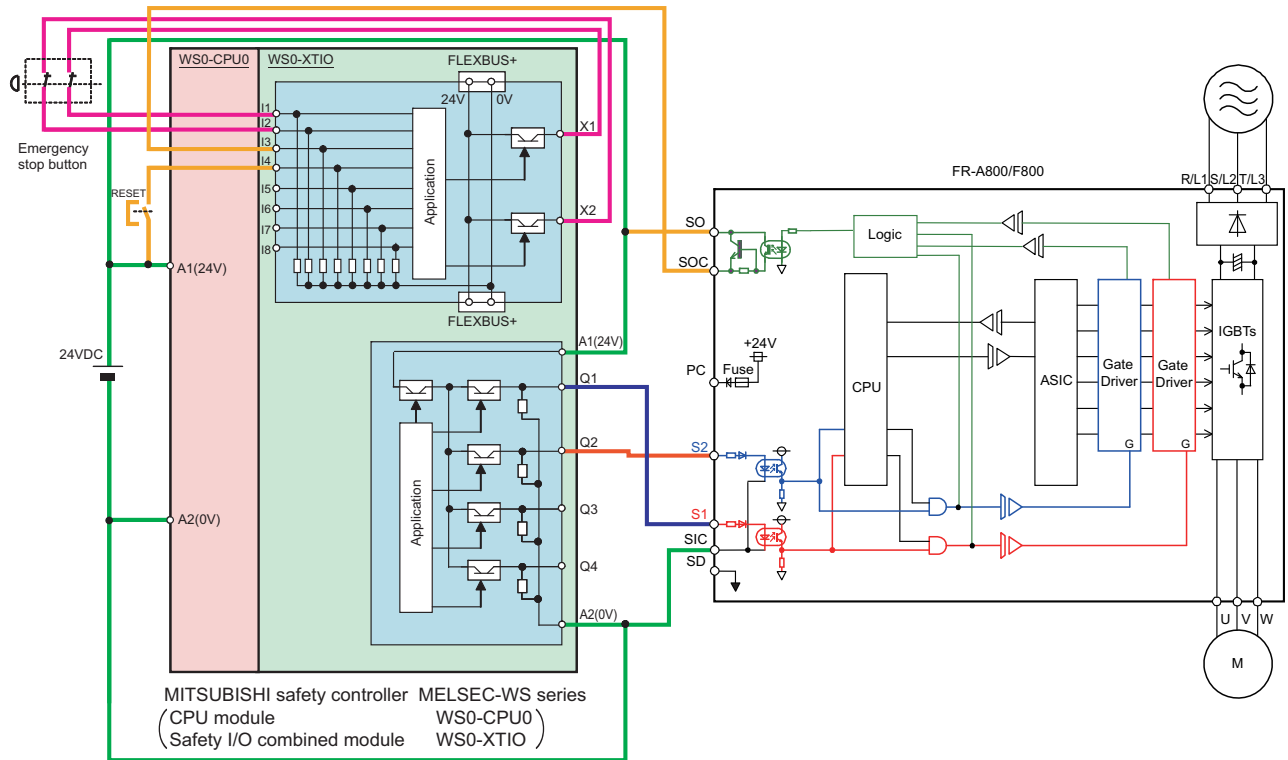

Fig.5 Safety system example with FR-A800/F800

NOTE

- When starting up the system's operation, press the RESET switch to reset the safety stop function first.
- In the above configuration, after reset of emergency stop button, drive will be in safe-state until RESET switch is pressed.

4 TEST AND CHECKING FAILURE

⚠ CAUTION

- To avoid systematic faults, a test even for faulty demands of the safety function has to be performed in order to check the correct function of the monitor signal. This test shall be carried out at system installation, any software changes, parameterization changes, and/or at least once per year.

I/O status and failure

FR-A800/F800 safety related I/O status obeys the following truth table.

Table.5 Truth table of safety related signals

Input power	Internal safety circuit status	Input terminal *1, *2		Output terminal	Inverter running status	Operation panel indication	
		S1	S2	SO		E.SAF *6	SA *7
OFF	—	—	—	OFF	Output shutoff (Safe state)	Not displayed	Not displayed
ON	Normal	ON	ON	ON *3	Drive enabled	Not displayed	Not displayed
	Normal	ON	OFF	OFF *4	Output shutoff (Safe state)	Displayed	Displayed
	Normal	OFF	ON	OFF *4	Output shutoff (Safe state)	Displayed	Displayed
	Normal	OFF	OFF	ON *3	Output shutoff (Safe state)	Not displayed	Displayed
	Fault	ON	ON	OFF	Output shutoff (Safe state)	Displayed	Not displayed *5
	Fault	ON	OFF	OFF	Output shutoff (Safe state)	Displayed	Displayed
	Fault	OFF	ON	OFF	Output shutoff (Safe state)	Displayed	Displayed
Fault	OFF	OFF	OFF	Output shutoff (Safe state)	Displayed	Displayed	

- *1 ON: The transistor is conducted. OFF: The transistor is not conducted.
- *2 When not using the safety stop function, short across terminals S1 and PC, S2 and PC, and SIC and SD to use the inverter. (In the initial status, terminals S1 and PC, S2 and PC, and SIC and SD are respectively shorted with shorting wires.)
- *3 If any of the protective functions shown in the following table is activated, the terminal SO turns OFF.

Error definition	Operation panel indication
Option fault.	E.OPT
Communication option fault	E.OP1
Parameter storage device fault	E.PE
Retry count excess	E.RET
Parameter storage device fault	E.PE2
Operation panel power supply short circuit/ RS-485 terminals power supply short circuit	E.CTE

Error definition	Operation panel indication
24 VDC power fault	E.P24
Safety circuit fault	E.SAF
Overspeed occurrence	E.OS
CPU fault	E.CPU
	E.5 to E.7
Internal circuit fault	E.13

- *4 If the internal safety circuit is operated normally, the terminal SO remains ON until E.SAF is displayed, and the terminal SO turns OFF when E.SAF is displayed.
- *5 SA is displayed when the terminals S1 and S2 are identified as OFF due to the internal safety circuit failure.
- *6 If another fault occurs at the same time as E.SAF, the other fault can be displayed.
- *7 If another warning occurs at the same time as SA, the other warning can be displayed.

NOTE

- The response time from safety stop signal input to drive shutoff (safe state) is faster than 8ms.
- Hold the ON or OFF status for 2ms or longer to input signal to terminal S1 or S2. Signal input shorter than 2ms is not recognized.

Diagnostic

If the failure detected, FR-A800/F800 output alarm signal and indicate 'E.SAF' at the display.

In case of FR-A800/F800 output the alarm, please take following action.

- 1) Check the S1-SIC and S2-SIC input signal logic is the same. If these are different logic, collect the input signal and reset the FR-A800/F800.
- 2) Disconnect the wire from S1, S2, SIC terminal, then reset or power-off and on. If the 'SA' letter is flashed up at display, there is failure in system except FR-A800/F800. But, still 'E.SAF' is displayed and alarm output, there is malfunction on FR-A800/F800.

Self diagnostic test

FR-A800/F800 does the self-diagnostic test on the power-ON.

If FR-A800/F800 output alarm (SA, E.SAF) at power-up, please take the action described in 'Diagnostic' at above.

Test procedure for functionality

As depicted 'CAUTION' in above, the test for the functionality is important.

Please do the test following procedure.

- 1) Please make each state of S1-SIC and S2-SIC depicted at Table.5.
- 2) If there is any different state from Table.5, FR-A800/F800 has some malfunction.
- 3) If there is no different state from Table.5, check the systematic performance, such as, press the emergency switch, press the start/restart button at the failure detected (SO-SOC opened), and so on.
- 4) Finally clear the error record of the FR-A800/F800 (see the user manual how to clear the error record).

5 SAFETY PARAMETERS OF FR-A800/F800

The safety parameters of FR-A800/F800 are depicted as follows.

Table.6 Safety parameters of FR-A800/F800

Parameter	Value
PFD _{AVG}	5.16×10^{-4}
PFHD	5.89×10^{-9}
PL	d
MTTFD	670 years
DC _{AVG}	60%

HEADQUARTERS

MITSUBISHI ELECTRIC EUROPE
EUROPE B.V.
German Branch
Gothaer Straße 8
D-40880 Ratingen
Phone: +49 (0) 21 02 / 486-0
Hotline: +49 2102 1805 000-765 /-766
Fax: +49 (0) 21 02 / 4 86-1 12 0
e mail: megfa-mail@meg.mee.com
www.mitsubishi-automation.com

MITSUBISHI ELECTRIC FRANCE
FRANCE
25, Boulevard des Bouvets
F-92741 Nanterre Cedex
Phone: +33 1 55 68 55 68
Fax: +33 1 49 01 07 25
e mail: factory.automation@fra.mee.com

MITSUBISHI ELECTRIC ITALY
EUROPE B.V.
Italian Branch
C.D. Colleoni-P. Perseo Ing. 2
Via Paracelso 12
I-20041 Agrate Brianza (MI)
Phone: +39 (0) 39 / 60 53 1
Fax: +39 (0) 39 / 60 53 312
e mail: factory.automation@it.mee.com

MITSUBISHI ELECTRIC SPAIN
EUROPE B.V.
Pol. Ind. Can Magi-C.
Calle Joan Buscallá, 2-4 AC 420
E-08190 Sant Cugat del Vallés
Phone: +34 (9) 3 / 565 31 31
Fax: +34 (9) 3 / 589 29 48

MITSUBISHI ELECTRIC UK
EUROPE B.V.
UK Branch
Travellers Lane
Hatfield, Hertfordshire, AL10 8 XB
Phone: +44 (0) 1707 / 27 61 00
Fax: +44 (0) 1707 / 27 86 95

MITSUBISHI ELECTRIC JAPAN
CORPORATION
Tokyo Bldg.
2-7-3 Marunouchi Chiyoda-Ku
Tokyo 100-8310
Phone: +81 (0) 3 / 32 18 31 76
Fax: +81 (0) 3 / 32 18 24 22

MITSUBISHI ELECTRIC USA
AUTOMATION
500 Corporate Woods Parkway
Vernon Hills, Illinois 60061
Phone: +1 (0) 847 / 478 21 00
Fax: +1 (0) 847 / 478 03 27

EUROPEAN REPRESENTATIVES

GEVA AUSTRIA
Wiener Straße 89
A-2500 Baden
Phone: +43 (0) 2252 / 85 55 20
Fax: +43 (0) 2252 / 488 60
e mail: office@geva.co.at

Getronics b.v. BELGIUM
Control Systems
Pontbeeklaan 43
B-1731 Asse-Zellik
Phone: +32 (0) 2 / 4 67 17 51
Fax: +32 (0) 2 / 4 67 17 45
e mail: infoautomation@getronics.com

TELECON CO. BULGARIA
4, A. Ljapchev Blvd.
BG-1756 Sofia
Phone: +359 92 / 97 44 05 8
Fax: +359 92 / 97 44 06 1
e mail: —

AutoCont CZECHIA
Control Systems s.r.o.
Nemocnicni 12
CZ-70200 Ostrava 2
Phone: +420 (0) 69 / 615 21 11
Fax: +420 (0) 69 / 615 21 12
e mail: —

louis poulsen DENMARK
industri & automation
Geminivej 32
DK-2670 Greve
Phone: +45 (0) 43 / 95 95 95
Fax: +45 (0) 43 / 95 95 91
e mail: lpia@lpmail.com

UTU Elektrotehnika AS ESTONIA
Pärnu mnt. 160i
EE-10621 Tallinn
Phone: +372 6 / 51 72 80
Fax: +372 6 / 51 72 88
e mail: utu@utu.ee

URHO TUOMINEN OY FINLAND
Hevosaankatu 3
FIN-28600 Pori
Phone: +358 (0) 2 / 55 08 00
Fax: +358 (0) 2 / 55 088 41
e mail: —

UTEKO A.B.E.E. GREECE
5, Mavrogenous Str.
GR-18542 Piraeus
Phone: +30 (0) 1 / 42 10 050
Fax: +30 (0) 1 / 42 12 033
e mail: uteco@uteco.gr

EUROPEAN REPRESENTATIVES

MITSUBISHI ELECTRIC IRELAND
EUROPE B.V.-Irish Branch
Westgate Business Park
Ballymount
IRL-Dublin 24
Phone: +353 (0) 1 / 419 88 00
Fax: +353 (0) 1 / 419 88 90
e mail: sales.info@meuk.mee.com

ALFATRADE LTD. MALTA
99 Paola Hill
Paola PLA 08
Phone: +356 / 697816
Fax: +356 / 697817
e mail: paul.licari@alfatrx.com

Getronics bv NETHERLANDS
Control Systems
Donauweg 10
NL-1043 AJ-Amsterdam
Phone: +31 (0) 20 / 586 15 92
Fax: +31 (0) 20 / 586 19 27
e mail: infoautomation@getronics.com

Beijer Electronics AS NORWAY
Teglverksveien 1
N-3002 Drammen
Phone: +47 (0) 32 / 24 30 00
Fax: +47 (0) 32 / 84 85 77
e mail: —

MPL Technology SP.Z.o.o POLAND
ul.Wroclawska 53
PL-30-011 Kraków
Phone: +48 (0) 12 / 632 28 85
Fax: +48 (0) 12 / 632 47 82
e mail: krakow@mpl.com.pl

Sirius Trading&Services srl ROMANIA
Bd. Ghica nr. 112, Bl. 41
RO-72335 Bucuresti 2
Phone: +40 (0) 1 / 210 55 11
Fax: +40 (0) 1 / 210 55 11
e mail: sirius_t_s@fx.ro

ACP AUTOCOMP a.s. SLOVAKIA
Chalupkova 7
SK-81109 Bratislava
Phone: +421 (0) 7 592 22 54
Fax: +421 (0) 7 592 22 48
e mail: —

INEA d.o.o. SLOVENIA
Ljubljanska 80
SI-1230 Domžale
Phone: +386 (0) 17 21 80 00
Fax: +386 (0) 17 24 16 72
e mail: inea@inea.si

EUROPEAN REPRESENTATIVES

Beijer Electronics AB SWEDEN
Box 426
S-20123 Malmö
Phone: +46 (0) 40 / 35 86 00
Fax: +46 (0) 40 / 93 23 02
e mail: —

ECONOTEC AG SWITZERLAND
Postfach 282
CH-8309 Nürensdorf
Phone: +41 (0) 1 / 838 48 11
Fax: +41 (0) 1 / 838 48 12
e mail: —

GTS TURKEY
Darülaceze Cad. No. 43A KAT: 2
TR-80270 Okmeydani-Istanbul
Phone: +90 (0) 212 / 320 1640
Fax: +90 (0) 212 / 320 1649
e mail: —

EURASIAN REPRESENTATIVES

MITSUBISHI ELECTRIC RUSSIA
EUROPE B.V.
12/1 Goncharnaya St, suite 3C
RUS-109240 Moscow
Phone: +7 (0) 95 / 915-8624/02
Fax: +7 (0) 95 / 915-8603
e mail: —

STC Drive Technique RUSSIA
Poslannikov per., 9, str. 1
RUS-107005 Moscow
Phone: +7 (0) 95 / 786 21 00
Fax: +7 (0) 95 / 786 21 01
e mail: —

JV-CSC Automation UKRAINE
15, M. Raskovoyi St., Floor 10,
Office 1010
U-02002 Kiev
Phone: +380 (4) 4 / 238 83 16
Fax: +380 (4) 4 / 238 83 17
e-Mail: mkl@csc-a.kiev.ua

MIDDLE EAST REPRESENTATIVE

SHERF Motion Techn. LTD ISRAEL
Rehov Hamerkava 19
IL-58851 Holon
Phone: +972 (0) 3 / 559 54 62
Fax: +972 (0) 3 / 556 01 82
e mail: —



HEAD OFFICE: TOKYO BUILDING 2-7-3, MARUNOUCHI, CHIYODA-KU, TOKYO 100-8310, JAPAN